

**Burglar Resistant Roller Shutter****Burglary protection****RC4****tested according to DIN / TS 18194****Tested additional function optional**

|                                 |                      |  |
|---------------------------------|----------------------|--|
| - Sound insulation              | up to $R_{wp}$ 38 dB | tested according to EN ISO 10140-2     |
| - Bullet resistance             | FB4-NS               | tested according to EN 1522            |
| - Air permeability              | up to class 3        | tested according to EN 12426 / 12427   |
| - Resistance against wind loads | up to class 4        | tested according to EN 12424 / 12444   |
| - Resistance against water      | up to class 2        | tested according to EN 12425 / 12489   |
| - Explosion protection          | up to zone 1/21      | according to EN 1127-1 or ATEX 94/9/EG |

**Range of dimension****Width up to 6000 mm**  
**Height up to 6000 mm****Technical description and tender specification**

|                             |   |
|-----------------------------|---|
| <b>Product:</b>             | <b>Burglar resistant rolling door made of light metal profiles brand Buchele tested according to DIN / TS 18194</b>   |
| <b>Door type:</b>           | <b>LM Line Type S</b>   |
| <b>Burglary protection:</b> | <b>RC 4</b>   |
| <b>Clear opening:</b>       | <b>.... x .... mm</b>   |
| <b>Rolling door blade:</b>  | <p>The door blade of the burglar resistant and both sides flush-mounted rolling door made of extruded light metal profiles is 60 mm thick. The patented single segments are 160 mm high and assembled in sandwich construction. The single segments are closed off by galvanized end pieces on both sides.</p> <p>The bottom segment is equipped with an elastic multi-chamber sealing profile towards the finished floor.</p> <p>The segments are connected by a continuous hook in lug integrated in the profile which allows that single door segments can be exchanged easily. The segment connections are covered by a sealing profile on the interior side of door.</p> <p>Each segment is equipped with a sealing profile integrated in the profile which guarantees the impermeability when the door is closed.</p> <p>Mechanical 2-point locking system<br/>Optional motorised 2-point locking system<br/>Surface bright raw.</p> <p>In order to protect the door blade against mechanical track marks on the blade a belt system (scratch protection) is optional supplied, which automatically unrolls and winds up and ensures a long lasting protection of the blade surface</p> |
| <b>Side guides:</b>         | <p>The two vertical side guides are made of a galvanized steel guide rail system, which holds the two mechanical sealing profiles in the guide rail fold.</p> <p>The mechanical sealing profiles are activated by a rocker tripped when door is closed.</p> <p>This rail system is mounted to the wall.<br/>Standard surface in RAL 7001.</p>   |

**Door fitting:** The drive shaft is placed on 2 massive steel consoles and there attached to ball-bearing liners. On concrete walls these steel consoles will be screwed to the wall, on brickwork walls they will be screwed to the wall with counter plates.  
After that the upper segments in connection with the optional belt system are mounted to the drive shaft. All following segments will be connected with the hook in lug integrated in the profile.

**Drive system:** Opening and closing of the door is provided by a 400 V three-phase drive with integrated maintenance and wear-free as well as position and speed independent safety catch.  
Emergency operation with emergency hand chain.  
The end position adjustment is done by electronic absolute encoders of optional by mechanical limit switches.

**Control unit:** The comfort automatic control system with integrated frequency converter for speed independent control of the door is suitable for a variety of applications.  
Standard scope of supply of the control unit is for operation in automatic mode, in connection with a light-curtain system, a combination device consisting of a flashing light and a signal horn and an electronic light grid system.  
In the removable cover of the control unit there are 3 push buttons and LEDs integrated for status information.  
The connection between control unit and drive is made with a ready for plugging preconfigured cable. (Cable length is customized in increments of 500 mm, depending on the clear height of the door).

### Optional features

**Explosion protection:** All electrical parts as well as the roll-off safety is available in explosion protected version ATEX tested.

**Metal covers:** A metal cover made of folded steel over the complete door blade. Several covered openings for maintenance purposes. Surface galvanized.

**Miscellaneous:** Upon request we supply any type of control elements.  
When ordering installation material the exact type and structure of the wall on which the door will be installed is required.

**BUCHELE DELUXE:** Door blade with exclusive surface coating.  
Door blade surface anodized  
Door blade surface powder coated

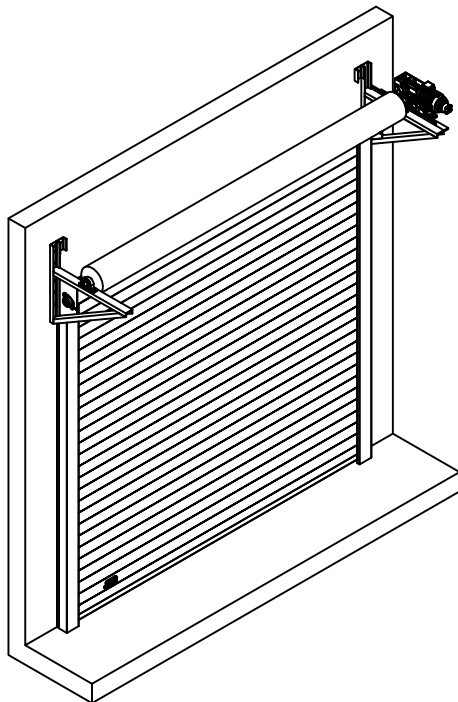
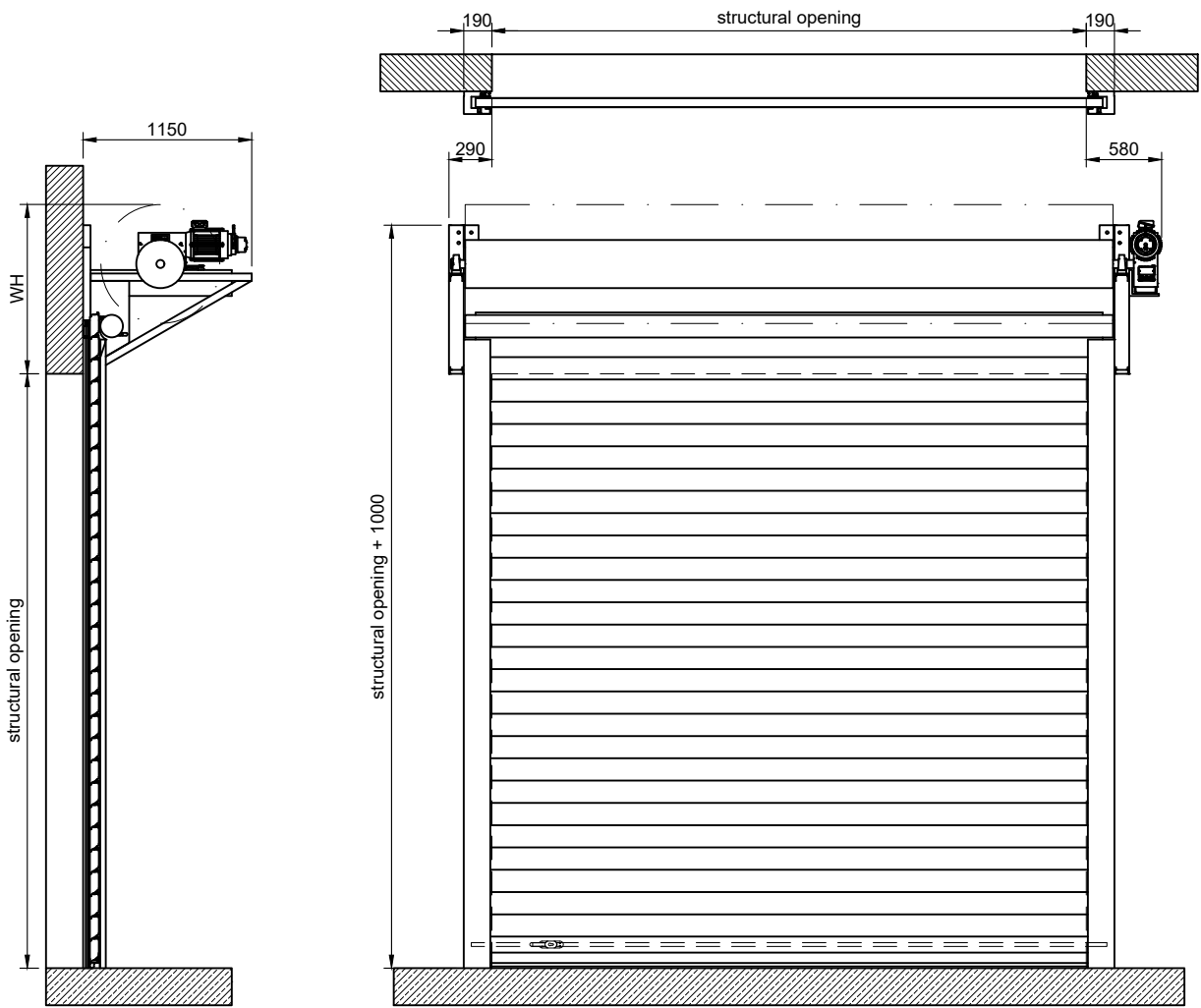

Optional with belt system

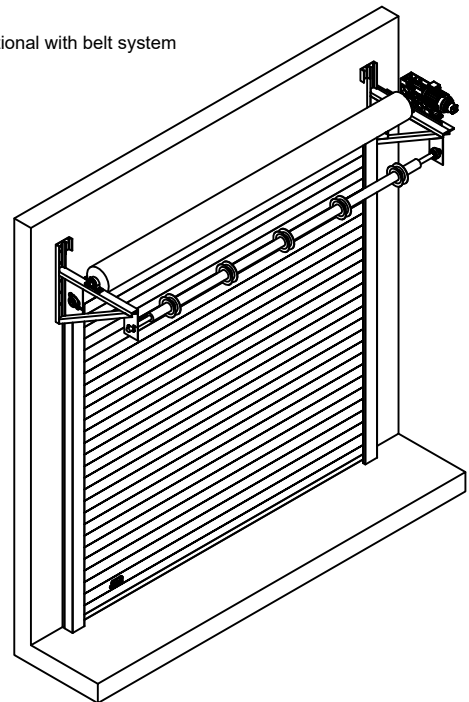

ROLLTOR\_KUNDENZEICHNUNG\_01

|                                  |      |      |      |      |      |      |      |
|----------------------------------|------|------|------|------|------|------|------|
| <b>Structural Opening Height</b> | 2000 | 2500 | 3000 | 3500 | 4000 | 4500 | 5000 |
| <b>WH</b>                        | 1100 | 1100 | 1150 | 1150 | 1200 | 1200 | 1250 |